



## Load Share Gateway (LSG)

### DESCRIPTION

The Load Share Gateway (LSG) is a next generation communication converter specifically designed to operate the easYgen-2000 / easYgen-3000 Series and legacy devices (RS-485 bus or analog load share line coupled) in one single load share network.

#### Example:

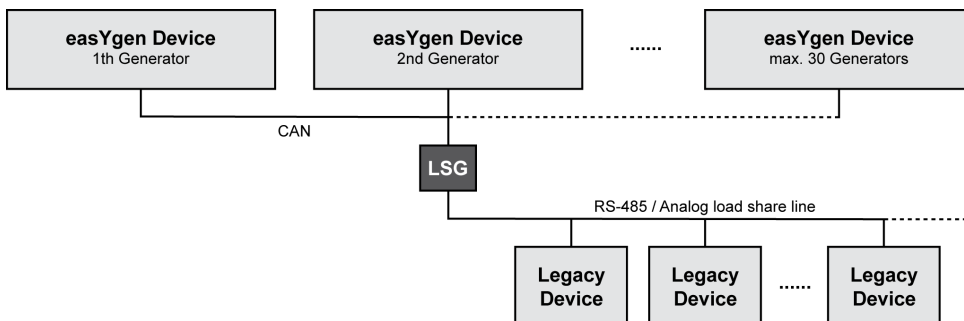

### FEATURES

- Easy and direct configuration via easYgen
- Converts CAN bus loadshare information into RS-485 data
- Converts CAN bus loadshare information to analog load share line
- Several analog load share line voltage ranges are selectable for a variety of analog load share devices
- Status LEDs for CAN & RS-485 communication are present
- Robust industrial grade metal housing
- LSG is visualized on the sequencing display screens on the easYgen

#### Technical requirements

The Load Share Gateway (LSG) works only in combination with:

- easYgen-3100/3200 (Package P2 – Software Version 1.12xx & 1.13xx)
- easYgen-3100/3200 (Software Version 1.15xx or higher)
- easYgen-3400/3500 (Software Version 1.17xx or higher)
- easYgen-2000 Series

- Ideal communication converter between easYgen-2000/3000 and legacy analog load share networks
- Easy and direct configuration via easYgen-2000/3000
- Preconfigured operating modes for legacy Woodward and third party devices
- Robust industrial grade aluminium housing
- CAN-to-RS-485 load share line gateway
- CAN-to-analog load share line gateway
- CE marked

# SPECIFICATIONS

Power supply.....12/24 Vdc (8 to 40 Vdc)  
 Intrinsic consumption .....max. 3 W  
 Ambient temperature (operation).....-20 to 70 °C / -4 to 158 °F  
 Ambient temperature (storage).....-30 to 80 °C / -22 to 176 °F  
 Ambient humidity.....60°C, 95% RH non-condensing, 5 days  
 .....IEC 60068-2-30, Test Db

**Housing**  
 Type .....Aluminium  
 Dimensions WxHxD ..... 141 × 98.5 × 21 mm  
 Connection..... screw/plug terminals 2.5 mm<sup>2</sup>  
 Protection system ..... IP20  
 Weight.....approx. 280 g  
**Disturbance test (CE)** ..... tested according to applicable EN guidelines

# DIMENSIONS

## Metal housing

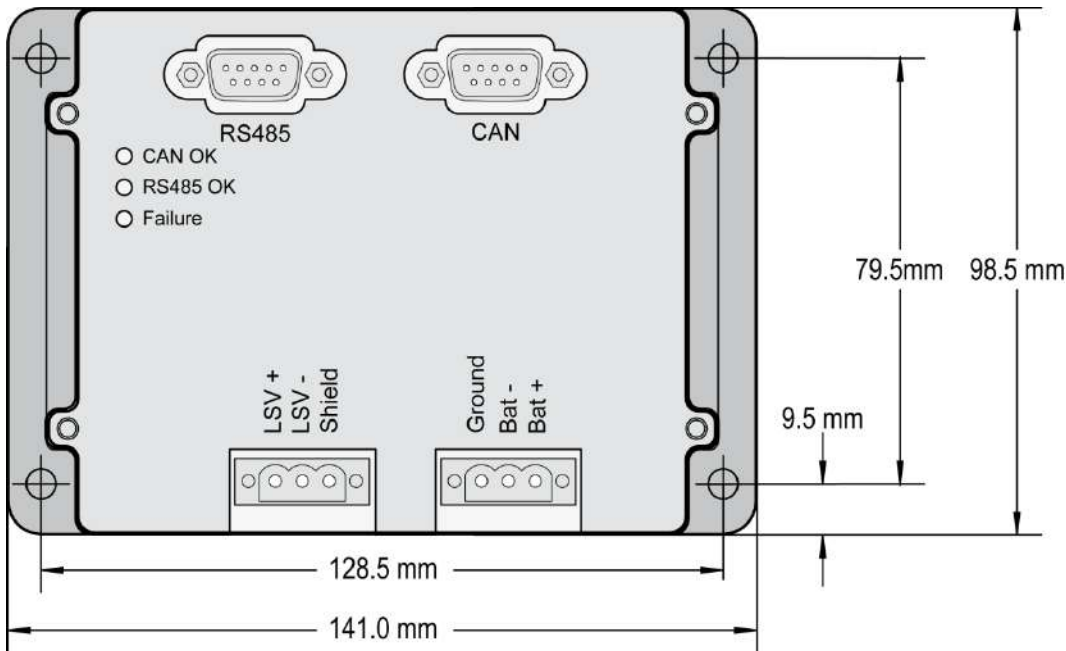

# TERMINAL DIAGRAM

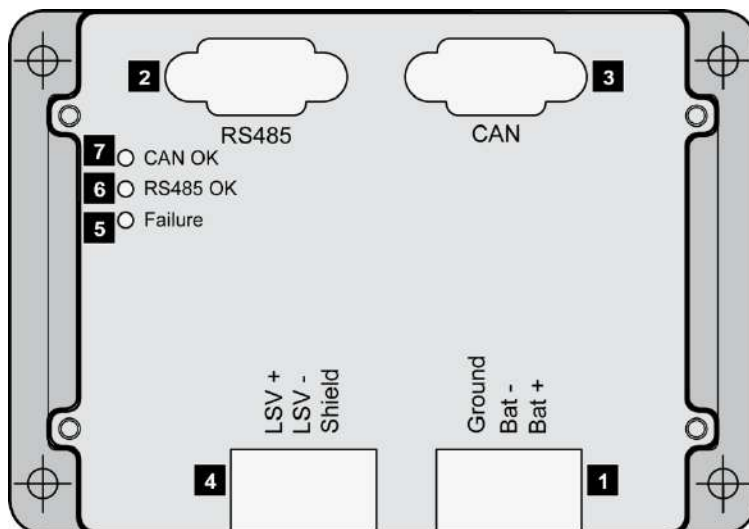

1. Power terminal block socket
2. RS-485 connector
3. CAN connector
4. Analog terminal block socket
5. Error indication LED
6. RS-485 / GCP/MFR CAN / Analog Status Indicator
7. easYgen (CAN) Communication Status LED

# APPLICATIONS

## easYgen connected to GCP/MFR (CAN)

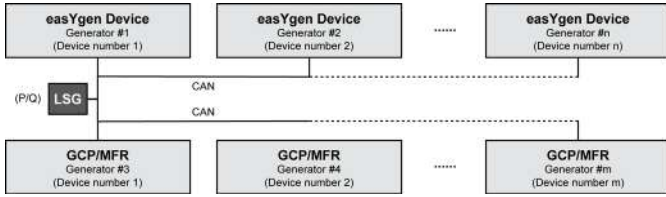

## easYgen connected to EGCP-2 (CAN/RS-485)

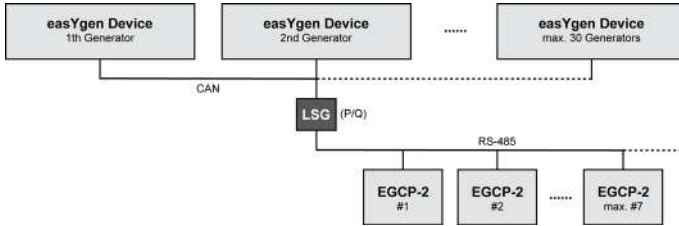

## easYgen connected to legacy device (CAN/Analog)

There are two application scenarios possible:

- Examples A shows the applications with one LSG for all easYgen devices
- Examples B shows the applications with one LSG for each easYgen devices

### Example A

Active power loadshare

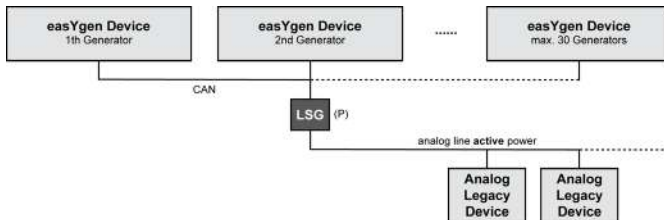

Active and reactive power loadshare

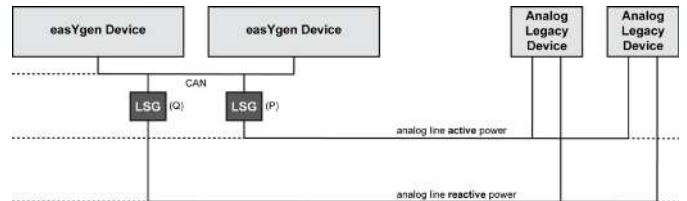

### Example B

Active power loadshare

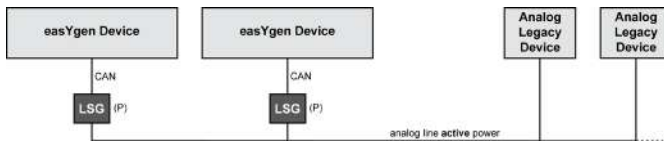

Active and reactive power loadshare

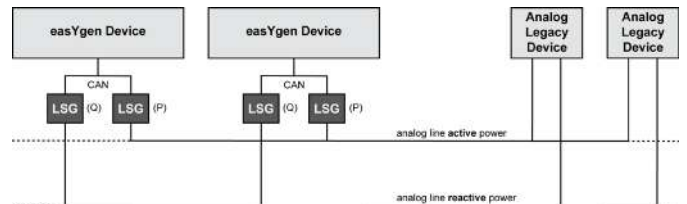

**International**

Woodward  
 PO Box 1519  
 Fort Collins CO, USA  
 80522-1519  
 1000 East Drake Road  
 Fort Collins CO 80525  
 Ph: +1 (970) 482-5811  
 Fax: +1 (970) 498-3058

**Europe**

Woodward GmbH  
 Handwerkstrasse 29  
 70565 Stuttgart, Germany  
 Ph: +49 (0) 711 789 54-0  
 Fax: +49 (0) 711 789 54-100  
 email: stgt-info@woodward.com

**Distributors & Service**

Woodward has an international network of distributors and service facilities. For your nearest representative, call the Fort Collins plant or see the Worldwide Directory on our website.

[www.woodward.com](http://www.woodward.com)

For more information contact:

Subject to technical modifications.

This document is distributed for informational purposes only. It is not to be construed as creating or becoming part of any Woodward Governor Company contractual or warranty obligation unless expressly stated in a written sales contract.

We appreciate your comments about the content of our publications. Please send comments including the document number below to  
 stgt-doc@woodward.com

© Woodward

**All Rights Reserved**

37451B - 2011/04/Stuttgart

# FEATURES OVERVIEW

	Model	Load Share Gateway (LSG)
<b>Supported devices</b>		
Woodward EGCP-2		RS-485 (P & Q) <sup>1</sup>
Woodward SPM-D		R <sup>2</sup> = 4.99k P <sup>3</sup> = 0 - 4V (0 to 100%) Q <sup>4</sup> = 0 - 5V (-85 to +85%)
MFR 15		R = 4.99k P = 0 - 4V (0 to 100%)
Woodward 2301 A		R = 54.90k P = 0 - 3V (0 to 100%)
Caterpillar LSM		R = 25.00k P = 0 - 3V (0 to 100%)
Cummins PCC 3100; PCC 3200; PCC 3201; PCC 3300		R = 5.00k P = 0 - 2.5V (-14.1 to +121.9%) Q = 0 - 2.5V (-16.7 to +125.3%)
POW-R-CON		R = 20.67k P = 0 - 5V (0 to 100%)
Prepared <sup>5</sup>		R = 25.00k P = -5 - +5V (0 to 100%)
Prepared <sup>5</sup>		R = 25.00k P = 0 - 7V (0 to 100%)
GCP/MFR		CAN (P & Q) <sup>1</sup> - easYgens and GCP/MFR share the same CAN bus
<b>I/Os</b>		
CAN bus load share line		✓
Analog load share line		✓
RS-485 load share line		✓
LED for CAN Status		✓
LED for RS485/Analog line Status		✓
LED for bus failure visualization		✓
<b>Listings/Approvals</b>		
CE Marked		✓
<b>Part Numbers</b>		
Active power load share gateway (P) <sup>3</sup>	P/N 8444-	1075
Re-active power load share gateway (Q) <sup>4</sup>	P/N 8444-	1074

<sup>1</sup> Operation mode supports one LSG device. This single device is able to share P and Q.

<sup>2</sup> R = Resistance

<sup>3</sup> P = Active power load share line range

<sup>4</sup> Q = Reactive power load share line range

<sup>5</sup> For Load Share devices that meet the specifications shown in the table above.